



● Features

- ✓ **Split off controller and keypad for high security**
- ✓ **Aluminum alloy casing designed with vandal resistant screws for enhanced safety & durability**
- ✓ **Narrow deftly dimension for narrow jambs**
- ✓ **Epoxy sealed for waterproof function against extremely harsh weather.**
- ✓ **Allows up to 200 + 10 users**
- ✓ **29-digit-code password protected design**
- ✓ **3 LED indicators & buzzer for status indication, keypad with beep sound**
- ✓ **Invalid PIN Lockout**
- ✓ **Additional input for Anti-Tailgating**
- ✓ **Non-Volatile Memory**
- ✓ **Dual relays output for multi-control**
- ✓ **Built-in tamper switch**

Note: DG-150 (Split design) DG-155 (Stand Alone)

● Statement

The DG-150/155 is a digital code-operated for access control keypad with up to 200+10 individual user PINs. Aluminum Alloy casing with vandal resistant screws, along with built-in tamper switch designed for enhanced safety and durability. Epoxy sealed for waterproof function against extremely harsh weather. Controller with backlit keypad and beep sound to avoid incorrect key-in.

Additional input to cut off time delay for auto-relocking and anti-tailgating function.

● Dimension

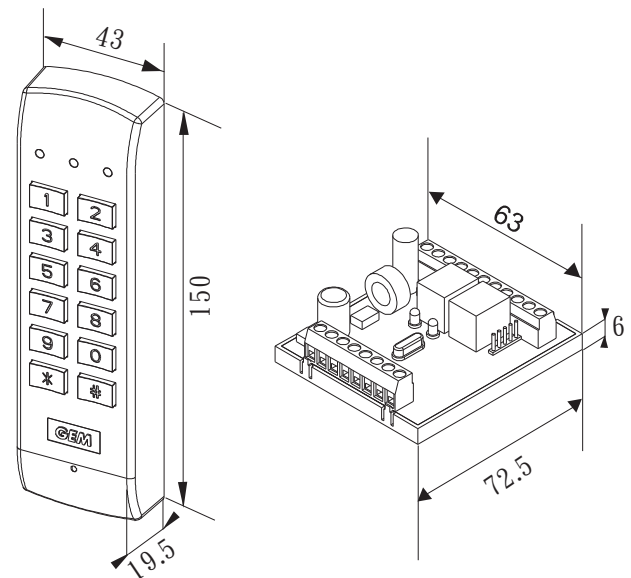

Unit: mm

● Specifications

- Operating Voltage: 12~24VAC/DC
- Current Draw : Holding:70mA, Pull in:130mA/12VAC/DC
Holding:50mA, Pull in:100mA/24VAC/DC
- Keypad: Backlit 6X2 matrix keypad (0~9,*,#)
- Input: 1 contact for Request-To-Exit button
1 contact for Door Reed Switch
- Output: 2 Relays (Dry Contacts: N.O./N.C./COM.)
- Relay Electric Current: Max.12A/14VDC; 7A/120VAC
- LED indicator: 3 LEDs (Red/Yellow/Green)
- Memory Volume : 200+10 PINs
- Relay Strike Time : 01~99 seconds or Toggle Mode(00)
- Ambient Humidity: 5~95%(Non-condensing)
- Operating Temperature: -20°C~70°C

● Warranty

The product is warranted against defects in material and workmanship while used in normal service for a period of 1 year from the date of sale to the original client. The GEM policy is one of continual development and improvement; therefore GEM reserves the right to change specifications without notice.

GIANNI INDUSTRIES, INC.

No. 13, Zhongxing Rd., Tucheng Dist., New Taipei City 236, Taiwan (R.O.C.)
Tel: 886-2 2267 7986 / Fax: 886-2 2267 9876
E-Mail: inquiry@gianni.com.tw
Website: gianni.tw